

Struvite precipitation assessment in anaerobic digestion processes

N. Marti^a, A. Bouzas^a, A. Seco^{a,*}, J. Ferrer^b

^a Dpto. Ingeniería Química, Universidad de Valencia, Doctor Moliner 50, Burjassot, 46100 Valencia, Spain

^b Dpto. Ingeniería Hidráulica y Medio Ambiente, Universidad Politécnica de Valencia, Camino de Vera s/n, 46022 Valencia, Spain

Received 11 April 2007; received in revised form 15 October 2007; accepted 18 October 2007

Abstract

Struvite precipitation causes important operational problems during the sludge treatment process, especially when EBPR sludge is treated. Predicting struvite formation is critical to be able to design process alternative that best minimises struvite precipitation. With this aim, phosphorus precipitation in an anaerobic digestion pilot plant was studied using experimental data and mass balance analysis. The results obtained showed significant phosphorus precipitation as struvite (58% of the fixed phosphorus) and a low precipitation of calcium phosphates (15%), forming mainly hydroxyapatite (HAP). The rest of the phosphorus fixed in the digester (27%) was attributed to adsorption processes on solid surfaces. The effect of pH and available phosphorus concentration on phosphorus fixation in the digester was also studied, indicating that a decrease of available $\text{PO}_4\text{-P}$ concentration in the digester can minimise phosphorus precipitation, reducing the maintenance problems associated with struvite deposits.

© 2007 Elsevier B.V. All rights reserved.

Keywords: Anaerobic digestion; EBPR; Phosphorus; Precipitation; Struvite

1. Introduction

Water quality legislation has increased the standards regarding nutrient removal in order to overcome eutrophication problems in receiving waters. Therefore, in recent years considerable attention has been paid to removing phosphorus from wastewaters.

The number of wastewater treatment plants (WWTPs) operated for enhanced biological phosphorus removal (EBPR) has increased worldwide. In EBPR processes, the application of an anaerobic–aerobic sequence enables the growth of polyphosphate accumulative microorganisms (PAO), which store great amounts of P as polyphosphates (Poly-P). Hence, the phosphorus load is transferred from the wastewater to the waste activated sludge which is later stabilized in a digestion process.

Stabilisation of sludge at large WWTPs is usually carried out by anaerobic digestion (AD). In this process, organic matter is transformed into CH_4 and CO_2 by the action of different groups of bacteria. The main advantages of this process are

the reduction in the volume of waste sludge and the production of methane gas that can be utilized to supply energy in the WWTP.

During anaerobic digestion of EBPR sludge, most of the phosphorus stored as Poly-P and part of the phosphorus present in the organic matter is released. The phosphorus that is released in the anaerobic digester may precipitate as metal phosphates causing operational problems in the sludge line. Accumulation of struvite ($\text{MgNH}_4\text{PO}_4\cdot 6\text{H}_2\text{O}$) on pipe walls and equipment surfaces of anaerobic digestion and post-digestion processes is a frequent problem in the wastewater treatment industry [1]. Struvite deposits cause pipe blockages and fouling pumps, leading to an important increase in the cost of the sludge management operations.

Struvite precipitation occurs when the combined concentrations of Mg^{2+} , NH_4^+ and PO_4^{3-} exceed the struvite solubility product. Struvite solubility is a function of the pH. As pH increases, struvite solubility decreases. Anaerobic digestion processes, which show a higher pH than the previous stages of the wastewater treatment, are more susceptible to struvite formation.

Struvite precipitation is not simply a problem of BNR treatment works [2]. EBPR processes, which produce a Poly-P rich waste sludge, exacerbate struvite deposit problems in anaerobic sludge digestion. Therefore, in these cases, special attention must be paid to minimise struvite deposits in order to reduce the cost of the sludge treatment line maintenance.

Abbreviations: EBPR, enhanced biological phosphorus removal; HAP, hydroxyapatite ($\text{Ca}_5(\text{PO}_4)_3\text{OH}$); MAP, struvite ($\text{MgNH}_4\text{PO}_4\cdot 6\text{H}_2\text{O}$); P, phosphorus; PAO, polyphosphate accumulating organisms; Poly-P, polyphosphate; PPS, pre-fermented primary sludge; WWTP, waste water treatment plant.

* Corresponding author. Tel.: +34 963544326; fax: +34 963544898.

E-mail address: aurora.seco@uv.es (A. Seco).

Nomenclature

TCOD	total chemical oxygen demand (mg/l)
TP	total phosphorus concentration (mg/l)
TS	total solids (mg/l)
TVS	total volatile solids (mg/l)
VFA	volatile fatty acid concentration (mgHAc/l)

Subscripts

av	available
ef	effluent
fix	fixed
in	influent
ORGrel	release from organic matter degradation
PAOrel	release from Poly-P hydrolysis
prec	precipitated
rem	remove
TOTrel	total release

The reduction of uncontrolled struvite precipitation in digesters also increases the efficiency of a possible post-digestion phosphorus recovery process. The crystallization of struvite is one of the most widely recommended technologies for recovering phosphorus from sludge digester liquors.

The aim of this work is to assess phosphorus precipitation in anaerobic digesters from routine experimental analysis and simple mass balances. Predicting struvite precipitation is critical to be able to design sludge management alternatives that best minimises uncontrolled phosphorus precipitation, reducing operational costs and enhancing phosphorus recovery in WWTP.

2. Materials and methods

2.1. Pilot plant

Pre-fermented primary sludge (PPS) from a fermentation/elutriation pilot plant [3] and waste activated sludge from an EBPR pilot-scale process [4] were fed to the anaerobic digestion pilot plant. The three plants were located in the WWTP of Carraixet, which is near the city of Valencia (Spain).

The anaerobic digestion pilot plant, as shown in Fig. 1, consists of three main components: a gravity thickener, an anaerobic digester, and a secondary digester. The anaerobic digester was a completely mixed type reactor of 160 l of effective volume. It was provided with five effluent discharges in order to provide broad operational flexibility in accordance with the working volume chosen. The content of the digester was completely mixed by the recirculation of the tank content using alternative pumping cycles. The reactor was equipped with redox, pH, and temperature electrodes. A data acquisition program was used to continuously store the monitored information of the process. A positive displacement diaphragm gas meter quantified the volume of biogas produced in the reactor. Digested sludge was collected in a 61-l storage tank for later dewatering by centrifugation.

2.2. Experimental procedure

The start up of the process was carried out in January 2004, with sludge from the anaerobic digester of the Carraixet WWTP. At the end of March, experimental analyses (specific gas production, SGP, TVS and COD removal) showed that steady state conditions had been reached. From March to June (3 months) steady conditions were maintained. In this period anaerobic digestion and precipitation processes were studied in the

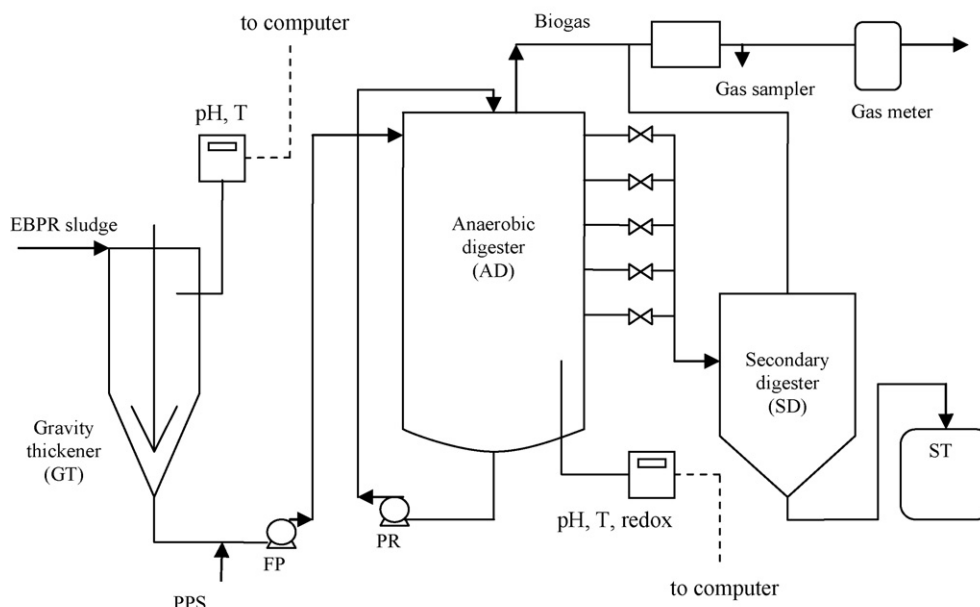

Fig. 1. Anaerobic digestion pilot plant. EBPR sludge: waste activated sludge from EBPR process; PPS: primary pre-fermented sludge; FP: feed peristaltic pump; RP: recirculation sludge pump; ST: storage tank for digested sludge.

Table 1
Experimental data of digester influent and effluent

	Influent		Effluent	
	Average	S.D.	Average	S.D.
TS (mg/l)	37,257	8444	18,554	3024
TVS (mg/l)	23,194	4403	10,484	1683
TCOD (mg/l)	40,650	8129	16,600	2623
TP (mg/l)	1,020	102	985	22
PO ₄ -P (mg/l)	71	20	152	26
NH ₄ -N (mg/l)	104	52	617	69
K ⁺ (mg/l)	72	17	237	27
Mg ²⁺ (mg/l)	60	17	12	7
Ca ²⁺ (mg/l)	151	42	50	16
VFA (mgHAc/l)	762	272	120	45
pH	–	–	7	–

S.D.: standard deviation.

digester. Results showed in this work belong to the stationary operation of the digester.

The working volume in the digester was set at 135 l and the retention time was set at 20 days. The anaerobic digestion process was operated at mesophilic conditions ($T = 35 \pm 1$ °C) and at a solids retention time (SRT) of 20 days.

PPS and EBPR sludge were first thickened separately and the mixed together (51% and 49%, respectively) in the influent pipe just before entering the reactor. Table 1 shows the experimental data of the feed sludge (influent) and the digested sludge (effluent) for the experimental period. The characteristics of the feed sludge varied widely during the experiment due to the variability of the sewage water.

2.3. Experimental analysis

Total solids (TS), total volatile solids (TVS), total COD (TCOD), and total phosphorus (TP) were performed in accordance with the standard methods [5]. The volatile fatty acids and alkalinity were measured daily using the five-point titration method [6]. The composition of VFA was analyzed using a gas chromatograph (6890N Agilent Tech.) equipped with a FFAP capillary column employing flame ionization detector (FID) under the following conditions: injector temperature 200 °C, detector temperature 250 °C and carrier gas He with a gas flow rate of 15.5 ml/min. The injected sample volume was 1 μ l. Initial oven temperature was fixed at 80 °C for 1 min and then ramped at 20 °C/min until 120 °C, which was maintained for 7 min. Finally, a temperature of 220 °C was achieved in order to purge the column.

Soluble Ca²⁺, Mg²⁺, K⁺ in the sludge samples were performed by means of atomic absorption spectrometry according to standard methods [5]. PO₄-P and NH₄-N were determined using spectrophotometry according to the standard methods [5]. Biogas composition (CO₂, N₂, and CH₄) was analyzed by gas chromatography separation (6890N Agilent Tech.) with two capillary columns (HP-PLOT Molesieve and HP-PLOT Q) and thermal conductivity detector (TCD). Injector and detector temperatures were fixed at 110 °C and 25 °C, respectively. Oven temperature was maintained at 40 °C for 12.5 min. The

carrier gas was He and the flow rate used was constant at 4 ml/min.

3. Results

3.1. Digestion process performance

The average organic loading rate (OLR) during the experimental period was 1.2 ± 0.2 gTVS/(l day). The average values achieved for TVS removal and COD removal were $55 \pm 8\%$ and $60 \pm 9\%$, respectively.

The specific gas production (SGP) was around 0.94 ± 0.27 l/gTVS_{rem}. A wide range of values in the biogas production was obtained as a consequence of the variation in the loading of volatile solids. Biogas composition was also determined obtaining $64 \pm 1\%$ of CH₄, $31 \pm 1\%$ of CO₂, $4 \pm 1\%$ of N₂ and $1 \pm 0.5\%$ of SH₂.

Process stability in the digester was assessed by means of pH, VFA concentration and alkalinity in the reactor. pH evolution was continuously monitored showing values in the range of 6.8–7.2. Average VFA concentration was 120 ± 52 mgHAc/l and the acetic acid percentage (%HAc) was $59 \pm 7\%$. Total alkalinity (Alk_T) was over 2000 ± 315 mgCaCO₃/l throughout the whole experimental period, which is a reference value for a well-stabilized digester [7]. VFA alkalinity (Alk_{VFA}) generated from VFA showed an average value of 255 ± 62 . The average ratio Alk_{VFA}/Alk_T was 0.11 ± 0.06 .

3.2. Precipitation assessment in the digester

An intensive analytical campaign was carried out on the influent and effluent digester stream during the steady state period. The evolution of Ca²⁺, Mg²⁺, K⁺, and PO₄-P concentrations are shown in Fig. 2.

As Fig. 2 shows, Ca²⁺ concentration decreased in the digester due to the precipitation of calcium salts. There was a similar decrease for Mg²⁺ which proves that magnesium precipitation also occurred. Unlike calcium, magnesium is a Poly-P counterion so an increase in Mg²⁺ concentrations due to Poly-P hydrolysis was expected. K⁺ concentration increased because of Poly-P hydrolysis and also because there is no potassium chemical fixation in the digester. Finally, PO₄-P concentration in the effluent was higher than in the influent. Since phosphorus release and precipitation are simultaneous processes during anaerobic digestion, the presence or absence of phosphorus precipitation cannot be concluded with the data obtained.

Therefore, in order to study the fate of phosphorus in the digester, a simple method based on PO₄-P, Ca²⁺, Mg²⁺, and K⁺ mass balances has been developed based on the following assumptions:

- Phosphorus stored as Poly-P is completely hydrolyzed during anaerobic digestion [8,9].
- The release of phosphorus is followed by a release of potassium and magnesium at the same ratio as observed during the phosphorus uptake [9]. Previously determined experimental values of 0.354 gK/gP and 0.283 gMg/gP were used [10].

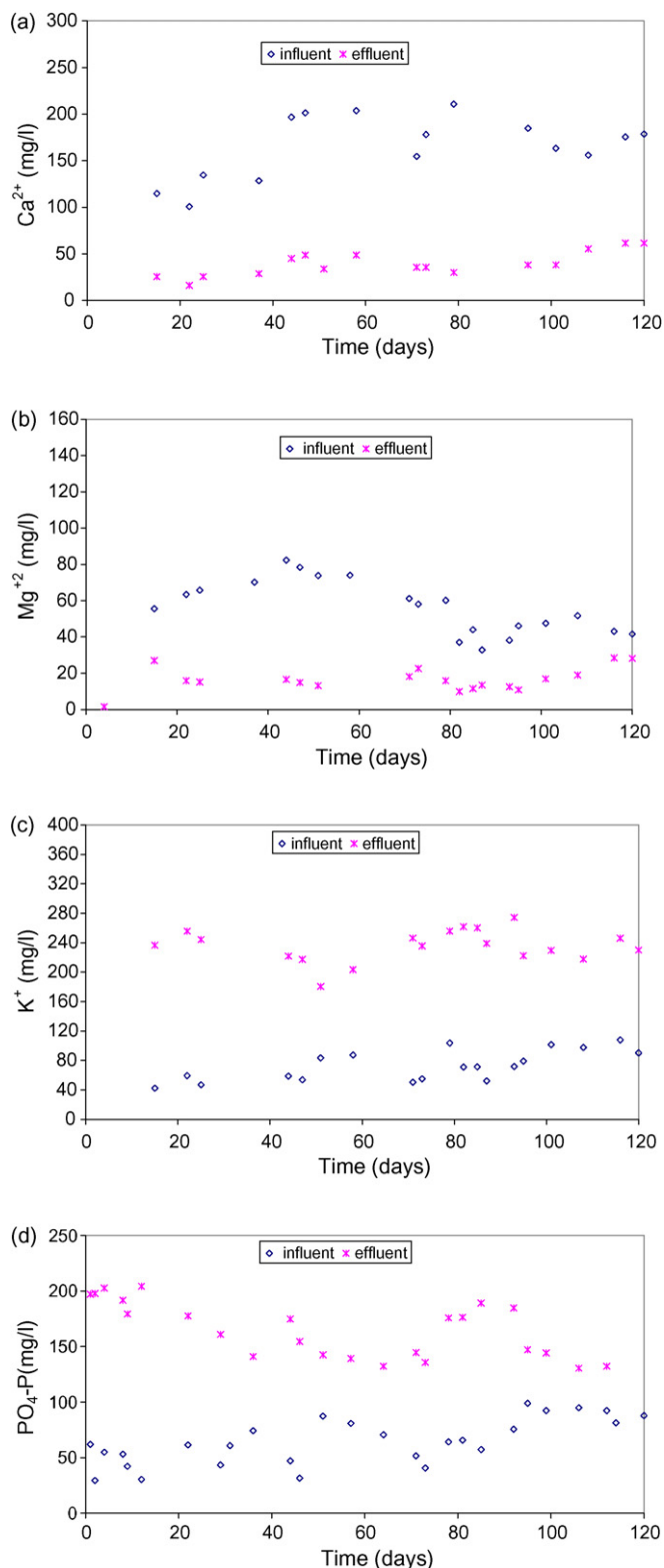

Fig. 2. Influent and effluent digester concentrations (a) Ca^{2+} , (b) Mg^{2+} , (c) K^{+} and (d) $\text{PO}_4\text{-P}$.

- Organic matter degradation produces a release of phosphorus, potassium, magnesium, and calcium associated with the content of each element in the organic matter (see Section 3.2.1).

- There is no chemical fixation of the potassium released in the digester. Different authors [11,12] have observed that potassium struvite ($\text{KMgPO}_4 \cdot 6\text{H}_2\text{O}$) could precipitate instead of ammonium struvite (MAP) in the case of low ammonium concentrations. However, in this study there was a high concentration of ammonium in the anaerobic digester (see Section 3.2.2).

3.2.1. P, K, Mg and Ca content in the organic matter

Phosphorus, magnesium, potassium, and calcium are present in wastewaters [13], as organic or inorganic forms, so they can be found in the sludge. During anaerobic digestion, part of the organic P, K, Mg, and Ca are released as a consequence of organic matter degradation. This makes it necessary to determine the organic content of P, K, Mg, and Ca in the sludge.

Since the anaerobic digester was fed with a mixture of PPS and EBPR sludge, it was necessary to distinguish the organic phosphorus, potassium, magnesium, and calcium content in the two types of substrate.

Experimental analyses of PPS (data not shown) and previous studies on the process [3] were used to estimate P, K, and Mg content in the organic fraction of the primary sludge (Table 2). Calculations were made taking into account that the suspended P, K, and Mg were associated to organic matter. This assumption can be made since no precipitation of P, K, and Mg was found in the primary sludge. However, it is impossible to accurately determine the calcium content in the organic matter of primary sludge due to its high inorganic content.

In the EBPR sludge, it is not possible to distinguish between the organic P, Mg, and K content and the content associated with Poly-P structure. Also, the organic matter in EBPR sludge is mainly biomass. Therefore, reported values for biomass composition [14] were assumed in the EBPR sludge (Table 2).

In accordance with the above discussion, the organic content of P, K, Mg, and Ca in the mixed influent sludge was calculated using the 51–49% proportion of PPS and EBPR sludge, and the values shown in Table 2.

3.2.2. Potassium struvite precipitation

The low participation of potassium in precipitation or adsorption reactions in wastewater and sludge treatment has been previously stated [15]. However, to confirm the assumption that potassium struvite does not precipitate under the current conditions in the digester, the potassium struvite saturation index (SI) was calculated. The SI was used to describe the saturation state of the aqueous phase composition for different solids (Eq.

Table 2
Organic P, K, Mg and Ca in primary, secondary and mixed sludge

	Primary sludge ^a	Biomass ^{b,c}	Mixed sludge
P (mgP/mgTVS)	0.013	0.020	0.016
K (mgK/mgTVS)	0.003	0.008	0.005
Mg (mgMg/mgTVS)	0.005	0.004	0.005
Ca (mgCa/mgTVS)	–	0.004	0.002

^a Experimental data from the fermentation/elutriation pilot plant.

^b [14].

^c These values are used for EBPR sludge.

Table 3
SI in the anaerobic digestion for potassium struvite, MAP and HAP

	K_{SP}	SI
Potassium struvite	2.4×10^{-11}	-2.389
Struvite (MAP)	5.8×10^{-14}	1.462
Hydroxyapatite (HAP)	4.7×10^{-45}	12.497

(1). When $SI=0$, the solution is in equilibrium; when $SI<0$, the solution is undersaturated and no precipitation occurs; when $SI>0$, the solution is supersaturated and precipitation occurs spontaneously. Therefore, the SI values can be used to evaluate the effect of the solution conditions on the tendency and extent of the precipitation.

$$SI = \log \frac{IAP}{K_{SP}} \quad (1)$$

where IAP represents the ion activity product and K_{SP} represents the thermodynamic solubility product.

The potential precipitation of potassium struvite was evaluated through thermodynamic calculations according to the composition in the digester. The value of K_{SP} used for potassium struvite was 2.4×10^{-11} [16]. Table 3 shows the SI for potassium struvite, MAP, and HAP. The results prove that sludge composition in the digester is supersaturated for MAP and HAP formation whereas it is undersaturated for potassium struvite.

XRD analyses were also carried out with struvite and potassium struvite patterns to determine the precipitated solid found in a digester sludge pipe. The results obtained proved the presence of struvite ($MgNH_4PO_4 \cdot 6H_2O$) in the recovered precipitate (Fig. 3(a)). Although both patterns are similar, the diffraction peaks of the solid that was formed better match the struvite pattern.

3.2.3. Mass balances

Mass balances were carried out in the anaerobic digester in accordance with the assumptions stated above and taking into account the average concentrations of the influent and effluent streams (Table 1).

Phosphorus release by PAO (P_{PAOrel}) was calculated from dissolved potassium mass balance.

$$K_{TOTrel}(mg/l) = K_{ef} - K_{in} \quad (2)$$

$$P_{PAOrel}(mg/l) = \frac{K_{PAOrel}}{0.354} = \frac{K_{TOTrel} - K_{ORGrel}}{0.354} \quad (3)$$

Phosphorus fixed (P_{fix}) was calculated from the dissolved phosphorus mass balance (Eq. (4)). The percentage of fixed phosphorus ($\%P_{fix}$) was also obtained (Eq. (5)).

$$\begin{aligned} P_{fix}(mg/l) &= P_{in} + P_{ORGrel} + P_{PAOrel} - P_{ef} \\ &= P_{in} + P_{TOTrel} - P_{ef} \end{aligned} \quad (4)$$

$$\%P_{fix} = \frac{P_{fix}}{P_{in} + P_{TOTrel}} \times 100 = \frac{P_{fix}}{P_{av}} \times 100 \quad (5)$$

The precipitated magnesium was calculated from the dissolved magnesium mass balance (Eq. (6)). The amount of Mg released by PAO (Mg_{PAOrel}) was estimated as $0.283P_{PAOrel}$. The percentage of precipitated magnesium ($\%Mg_{prec}$) was obtained from Eq. (7).

$$Mg_{prec}(mg/l) = Mg_{in} + Mg_{PAOrel} + Mg_{ORGrel} - Mg_{ef} \quad (6)$$

$$\%Mg_{prec} = \frac{Mg_{prec}}{Mg_{in} + Mg_{TOTrel}} \times 100 \quad (7)$$

Finally, taking into account that calcium is only released by biomass organic solid degradation, the dissolved calcium mass balance was carried out to calculate calcium precipitation in the digester.

$$Ca_{prec}(mg/l) = Ca_{in} + Ca_{ORGrel} - Ca_{ef} \quad (8)$$

$$\%Ca_{prec} = \frac{Ca_{prec}}{Ca_{in} + Ca_{ORGrel}} \times 100 \quad (9)$$

The mass balance results are shown in Table 4. As this table indicates, 403 mg/l of phosphorus were fixed in the digester, which represents 73% of the available phosphorus (i.e., influent + release during anaerobic digestion). For magnesium, 184 mg/l were fixed (94% of the available magnesium). For calcium, 126 mg/l were fixed (72% of the available calcium).

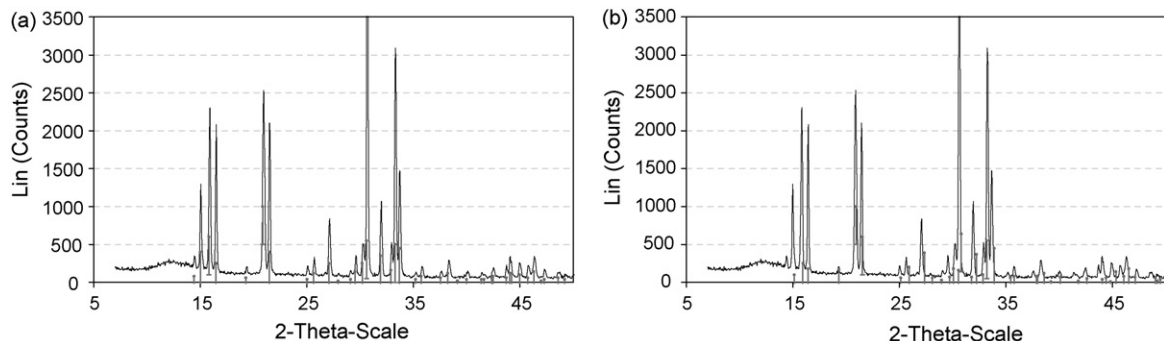

Fig. 3. XRD analyses for the solids formed in the digestion system. (a) Struvite pattern and (b) potassium struvite pattern.

Table 4
Potassium, phosphorus, magnesium and calcium balance in the digester

K _{TOTrel} (mg/l)	166
K _{ORGreI} (mg/l)	68
K _{PAOrel} (mg/l)	98
P _{PAOrel} (mg/l)	276
P _{ORGreI} (mg/l)	209
P _{TOTrel} (mg/l)	485
P _{fix} (mg/l)	403
%P _{fix}	73
Mg _{PAOrel} (mg/l)	78
Mg _{ORGreI} (mg/l)	57
Mg _{TOTrel} (mg/l)	136
Mg _{prec} (mg/l)	184
%Mg _{prec}	94
Ca _{ORGreI} (mg/l)	25
Ca _{prec} (mg/l)	126
%Ca _{prec}	72
%P-MAP	58
%P-HAP	15
%P-ad	27

According to the literature, four possible phosphate magnesium salts can precipitate from a solution containing Mg²⁺, NH₄⁺, and PO₄³⁻. These are: struvite (MgNH₄PO₄·6H₂O); magnesium hydrogen phosphate trihydrate or newberyite (MgHPO₄·3H₂O); trimagnesium phosphate in two states of hydration (Mg₃(PO₄)₂·22H₂O and Mg₃(PO₄)₂·8H₂O). These magnesium salts precipitate at different pH regions. Struvite precipitates at neutral and higher pH and at Mg/Ca molar ratios >6 [17]; newberyite at pH < 6 [18]; trimagnesium phosphates, which are reported to have a low precipitation rate [18], have never been identified in the pH range 6 < pH < 9. Also, precipitation of magnesite (MgCO₃) has not been considered due to its high solubility when compared to struvite. Therefore, magnesium was considered to precipitate in the digester mainly as struvite, which allowed us to estimate the amount of phosphate precipitated as struvite (%P-MAP), 58%.

The precipitated calcium in the digester was considered to form calcium phosphates. According to the Ostwald rule of stages, calcium phosphate formation takes place as a two-stage process. The phase that is thermodynamically less stable forms before the most stable phase, which is hydroxyapatite (Ca₅(PO₄)₃OH). In this work hydroxyapatite (HAP) was formed due to the high process retention time, i.e. 15% of fixed phosphorus was HAP.

The rest of the phosphorus fixed in the digester was considered to be adsorbed on the surface of the solids [8]. The results shown in Table 4 indicate that 27% of fixed phosphorus was adsorbed on the solid surface (%P-ad).

3.3. Influence of pH and available P concentration on P precipitation

The influence of pH and available phosphorus concentration (P_{av}) on phosphorus fixation in the digester was also been studied. Fig. 4 shows the phosphorus fixation (P_{fix}) as a function of operational pH. Given the high variability of the phosphorus available in the digester, three levels of available phospho-

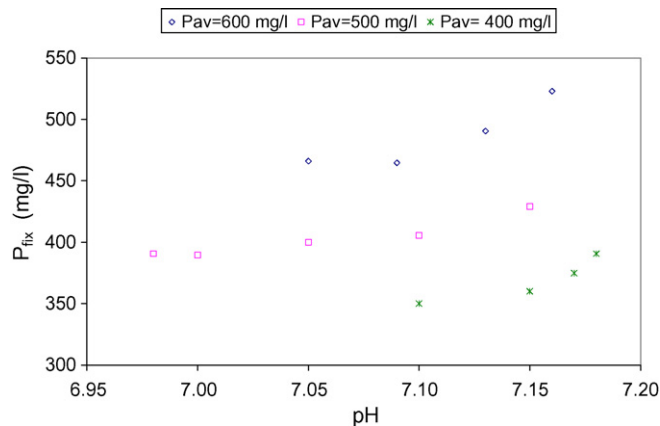

Fig. 4. Influence of pH and available phosphorus on phosphorus fixation.

rus concentration in the digester (~600 mg/l, ~500 mg/l, and ~400 mg/l) were considered. For similar P_{av} concentrations, phosphorus fixation increased for pH values above 7.10. For values below 7.10, no dependence was found. An increase in P_{fix} was also found in the digester at higher levels of P_{av}. These results suggest that decreasing the pH or the P_{av} in the digester will reduce, thereby reducing precipitation problems.

4. Discussion

With regard to the performance of the anaerobic digestion process performance, a high TVS and COD removal was achieved (55 ± 8% and 60 ± 9%, respectively) when compared with the typical values observed in anaerobic mesophilic digesters treating mixed sludges [19]. This fact was attributed to the high mixing power provided by the agitation pump, 0.1 W/l. Typical values for the power input required for mechanically mixed anaerobic digesters are in the range 0.005–0.008 W/l for normal agitation and 0.02 W/l for high agitation [19]. The high mixing power used in this experiment may cause higher bacterial structure destruction, thereby increasing volatile solid removal.

The specific gas production (SGP) was around 0.94 ± 0.27 l/gTVS_{rem}, in agreement with the literature data of 1 l/gTVS_{rem} observed when digesting primary and secondary sludges. Biogas composition showed 64% of methane content, a typical value found for proper anaerobic digestion processes.

Volatile fatty acid concentration (VFA) in the influent digester stream was high due to the great VFA concentration in the primary sludge as a consequence of the fermentation/elutriation process. However, VFA in the digester showed an average value of 120.0 mgHAc/l, which is a normal value for this parameter [7]. The composition of the VFA in the digester pointed out that acetic acid was the main constituent (59%). The ratio Alk_{VFA}/Alk_T, which is used as an indicator of the possible VFA accumulation in the reactor, was below 0.3. This value ensures the operational stability of the process, whereas an increase above 0.3–0.4 would indicate stability problems requiring corrective actions.

The results obtained concerning precipitation assessment in the digester showed a high phosphorus fixation as struvite. This result suggests that important operational problems and high

maintenance costs associated with struvite precipitation could be expected when working in an industrial WWTP under similar conditions.

Calcium phosphates were also precipitated in the digester. As explained above, HAP is thermodynamically the most stable phase. However, it has been established that other calcium phosphates, such as an amorphous calcium phosphate (ACP), act as precursors to the precipitation of HAP. Experimental studies have shown that the required time for the total conversion of ACP in HAP for a pH value of 7 is around 130 min [20]. Therefore, due to the high retention time in the digester (20 days), in our study, most of the calcium phosphates precipitated in the form of HAP.

Although calcium carbonate (CaCO_3) formation is also possible, it is not expected to precipitate in the digester due to crystal formation inhibition by phosphate [21,22]. Therefore, in the present work, due to the high phosphorus concentration in the digester, CaCO_3 was not considered to be a possible precipitate.

Our results also indicate that part of the fixed P was not precipitated but adsorbed on the solid surface. Although adsorption mechanisms in anaerobic digesters are difficult to quantify, different authors have suggested the possibility of this phosphorus fixation mechanism in anaerobic digesters [8,9].

The results concerning the influence of pH and available phosphorus concentration on phosphorus fixation showed that an increase in both parameters increases phosphorus fixation in the digester. Therefore, it would be possible to reduce P fixation by controlling these two parameters. However, since the operational pH in the digester cannot be easily modified because it is controlled by bacteria population in the reactor and by the bicarbonate buffering system, available phosphorus control should be used. Available phosphorus in the digester consists of the dissolved P concentration in the influent stream (P_{in}) and the P released during the anaerobic digestion process due to Poly-P hydrolysis (P_{PAOrel}) and organic solid degradation (P_{ORGrel}). To decrease P_{av} in the digester, Poly-P hydrolysis can be enhanced in a previous stage of the sludge treatment process, such as the gravity thickener. Mixed thickening of prefermented primary sludge (PPS) and EBPR sludge should be carried out. Moreover, the supernatant obtained in this thickener could be a suitable stream for phosphorus recovery by struvite crystallization. Our focus for further research will be focus on planning the best strategy for the sludge treatment in order to reduce struvite precipitation problems in digesters.

5. Conclusions

In this paper, a complete research study on the anaerobic digestion process at pilot scale has been carried out. Phosphorus release and precipitation in the system as well as an estimation of the possible inorganic compounds formed have also been assessed. The main conclusions are shown below:

- The anaerobic digestion process of PPS and EBPR sludge showed high efficiencies on TVS and COD removal (55% and 60%, respectively) due to the high mixing power provided by the agitation pump. Biogas production and composition

showed typical values for proper anaerobic digestion of mixed sludge.

- The precipitation study in the digester showed a high phosphorus fixation, mainly as struvite.
- Calcium phosphates were also precipitated in the digester. Due to the high retention time in the digester (20 days), most of them were in the form of HAP.
- Phosphorus adsorption on solid surfaces was also detected in the digester. More research is needed to determine to what extent phosphate adsorption takes place in anaerobic digesters.
- Phosphorus fixation in the digester increased with pH and available phosphorus concentration. The reduction of P_{av} in the digester can be considered as an alternative method for avoiding phosphorus precipitation. Phosphorus release from Poly-P hydrolysis prior to digestion by mixed thickening of sludges could be a strategy of sludge treatment to minimise precipitation problems in anaerobic digesters.

Acknowledgements

This research work has been supported by the Spanish Research Foundation (MCYT, project PPQ2002-04043-C02-02), which is gratefully acknowledged. Technical support from Entidad Pública de Saneamiento de Aguas Residuales de la Comunidad Valenciana is also gratefully acknowledged.

References

- [1] K.N. Ohlinger, T.M. Young, E.D. Schroeder, Predicting struvite formation in digestion, *Water Res.* 32 (1998) 3607–3614.
- [2] S.A. Parsons, J.D. Doyle, Struvite scale formation and control, *Water Sci. Technol.* 49 (2004) 177–182.
- [3] A. Bouzas, J. Ribes, J. Ferrer, A. Seco, Fermentation and elutriation of primary sludge: effect of SRT on process performance, *Water Res.* 41 (2007) 745–757.
- [4] F. García-Usach, J. Ferrer, A. Bouzas, A. Seco, Simulation and calibration of ASM2d at different temperatures in a phosphorous removal pilot plant, in: *Proceedings of the Nutrient Management in Wastewater Treatment Processes and Recycle Streams*, Krakow, 2005, pp. 681–689.
- [5] American Public Health Association (APHA), *Standard Methods for the Examination of Water and Wastewater*, 20th ed., APHA-AWWA-WPCF, Washington, DC, USA, 1998.
- [6] R.E. Moosbrugger, M.C. Wentzel, G.A. Ekama, G.v.R. Marais, Simple titration procedures to determine H_2CO_3 alkalinity and short-chain fatty acids in aqueous solutions containing known concentrations of ammonium, phosphate and sulphide weak acid/bases, *Water Res. Commission, Report No. TT 57/92*, University of Cape Town, Research Report W 74, Pretoria, Republic of South Africa, 1992.
- [7] H.W. Zhao, T. Viraraghavan, Analysis of the performance of an anaerobic digestion system at the Regina wastewater treatment plant, *Biores. Technol.* 95 (2004) 815–819.
- [8] D. Wild, A. Kisliakova, H. Siegrist, Prediction of recycle phosphorus loads from anaerobic digestion, *Water Res.* 31 (1997) 2300–2308.
- [9] N. Jardin, H.J. Pöpel, Phosphate release of sludges from enhanced biological p-removal during digestion, *Water Sci. Technol.* 20 (1994) 281–292.
- [10] R. Barat, T. Montoya, A. Seco, J. Ferrer, The role of potassium, magnesium and calcium in the enhanced biological phosphorus removal treatment plants, *Environ. Technol.* 26 (2005) 983–992.
- [11] R.D. Schuiling, A. Andrade, Recovery of struvite from calf manure, *Environ. Technol.* 20 (1999) 765–768.

- [12] J. Wilsenach, C.A.H. Schuurbiers, M.C.M. van Loosdrecht, Phosphate and potassium recovery from source separated urine through struvite precipitation, *Water Res.* 41 (2006) 458–466.
- [13] K. Kujawa-Reeleveld, G. Zeeman, Anaerobic treatment in decentralised and source-separation-based sanitation concepts, *Environ. Sci. Bio/Technol.* (5) (2006) 115–139 (Review).
- [14] Metcalf and Eddy Inc., *Wastewater Engineering: Treatment and Reuse*, McGraw-Hill Inc., New York, 2003.
- [15] S.A. Parson, F. Wall, J. Doyle, K. Oldring, J. Churchley, Assessing the potential for struvite recovery at sewage treatment works, *Environ. Technol.* 22 (2001) 1279–1286.
- [16] A.W. Taylor, A.W. Frazier, E.L. Gurney, *Trans. Faraday Soc.* 59 (1963) 1580–1584.
- [17] E.V. Musvoto, M.C. Wentzel, G.A. Ekama, Integrated chemical-physical processes modelling. II. Simulating aeration treatment of anaerobic digester supernatants, *Water Res.* 34 (2000) 1868–1880.
- [18] D. Mamais, P.A. Pitt, Y.W. Cheng, J. Loiacono, D. Jenkins, Determination of ferric chloride dose to control struvite precipitation in anaerobic sludge digester, *Water Environ. Res.* (1994) 912–918.
- [19] C.P.L. Grady, G.T. Daigger, H.C. Lim, *Biological Wastewater Treatment*, 2nd ed., Marcel Dekker Inc., New York, 1999.
- [20] L. Montrastruc, C. Azzaro-Pantel, B. Biscans, M. Cabassud, S. Domenech, A thermochemical approach for calcium phosphate precipitation modelling in a pellet reactor, *Chem. Eng. J.* 94 (2003) 41–50.
- [21] E.P.A. Van Langerak, M.M.H. Beekmans, J.J. Beun, H.V.M. Hamelers, G. Lettinga, Influence of phosphate and iron on the extent of calcium carbonate precipitation during anaerobic digestion, *J. Chem. Technol. Biotechnol.* 74 (1999) 1030–1036.
- [22] L.J. Plant, W.A. House, Precipitation of calcite in the presence of inorganic phosphate, *Colloid Surf. A: Physicochem. Eng. Aspects* 203 (2002) 143–153.